

# User Manual

Floor distributor CCU-4GF



[www.commax.com](http://www.commax.com)

**COMMAX Co., Ltd**



- Thank you for purchasing COMMAX products.
- Please carefully read this User's Guide (in particular, precautions for safety) before using a product and follow instructions to use a product exactly.
- The company is not responsible for any safety accidents caused by abnormal operation of the product.

# PDE Compressor Free Version



## Contents

1. Introduction .....	2
2. Important Safeguard .....	3
3. Main function and caution .....	4
4. Wiring .....	6
5. Specification.....	8

# PDF Compressor Free Version



## 1. Introduction

Your unit is designed so it can be flush mounted on the or used. When flush mounted on the wall, the stand permits you to the unit for an gular of unit view. The model number is located on the bottom and record the serial number in the space provided below(available). Refer to these numbers whenever you call upon your COMMAX dealer regarding this product.

Model No.

Serial No.

**To prevent fire or shock hazard, do not expose the unit to rain or moisture.**



This symbol is intended to alert the use to the presence of uninsulated **\*dangerous Voltage\*** within the product's enclose that may be of sufficient magnitude to constitute a risk of electric shock to persons.



This symbol is intended to alert the use to the presence of important operating and maintenance(servicing) instructions in the literature accompanying the appliance



Caution

Risk of electric shock  
do not open



CAUTION : To reduce the risk of electric shock, do not remove cover(or back) no user-serviceable part inside refer servicing to qualified service personnel

# PDF Compressor Free Version



## 2. Important Safeguards

- ▲ **Damage Requiring Service** : This equipment from the power source and source and refer servicing to qualified service personnel under the following conditions
  - Ⓐ when the power is damaged.
  - Ⓑ if liquid has been spilled or objects have fallen into the unit.
  - Ⓒ if the equipment has been exposed to rain or water.
  - Ⓓ if the equipment has been dropped or otherwise damaged.
  - Ⓔ when the equipment exhibits a distinct change in performance- this indicates a need for service.
- ▲ **Water and Moisture** : Do not use this product near water, for example, near a bath tub, wash bowl, kitchen sink, or laundry tub, in a wet basement, or near a swimming pool, and the like.
- ▲ **Accessories** : The product may fall, causing serious injury to a child or adult, and serious damage to the appliance. Any mounting of the manufacture' s instructions, and should use a mounting accessory recommended by the manufacturer.
- ▲ **Object and Liquid Entry** : Never push objects of any kind into this product through openings as they may touch dangerous voltage points or short-out parts that could result in a fire or electric shock. Never spill liquid of any kind on the product.
- ▲ **Lightning** : For added protection for this product before a lightning storm, or when it is left unattached and un used for long periods of time, unplug it from the wall outlet and disconnect the other system. This will prevent damage to the product due to lightning and power-line surges. If you live in an aread heavily prone to lightning storms, it is recommended that you invest in power-line, telephone-line, RF cable and actuator / polarization surge protectors to protect your appliance system from possible damage

# PDF Compressor Free Version



## 3. Main function and caution

- ① CCU-4GF is used by connecting with Line PCB of DRC-GAC/GAB which is the Gate View Lobby Phone for export and at construction site, CCU-4GF is developed to extend and to make up for the problem when IN-OUT wiring is impossible.

Lobby Phone : DRC-GAC/GAB UTP

Export Guard Phone : CDS-4GS

Household Video Phone : Gate View System Video Product line

- ② Caution when wiring CCU-4GF (we do not guarantee the quality of product on wiring which is not obeyed the following particles.)

- In "IN" of CCU-4GF, output DRC-GAC\_LINE or, connect "OUT" of CCU-4GF installed in downstairs.
- "LINE1~4" of CCU-4GF should be wired the video phone of Gate View System on the floor installed CCU-4GF.(Connect max 4 households)
- CCU-4GF is entered common 8 lines of Gate View System and separates the wiring till 4 households on the relevant floor and output common 8 lines to next

# PDF Compressor Free Version

floor.

- Within max 300m, CCU-4GF should be used less than 40 units.
- In CCU-4GF, the distance to the video phone of Gate View on the relevant floor should be within 20m
- CCU-4GF should be connected with the additional power. (More than DC12V/500mA)
- Power(DC12V / 500 mA) input is basically installed one power per one CCU-4GF. But, if you attempt to use one power in common for the reason of installation, pay attention not to exceed within 30m of max power line, max 5 of connection number.
- As this equipment(CCU-4GF) is the floor distributor possible to be interlocked with Gate View Lobby Phone[DRC-GAC/GAB], it won't work normally while interlocking with other extension equipment  
(This product is not compatible with VD-103.If needed, use VD-103(N))

# PDF Compressor Free Version

## 4. Wiring

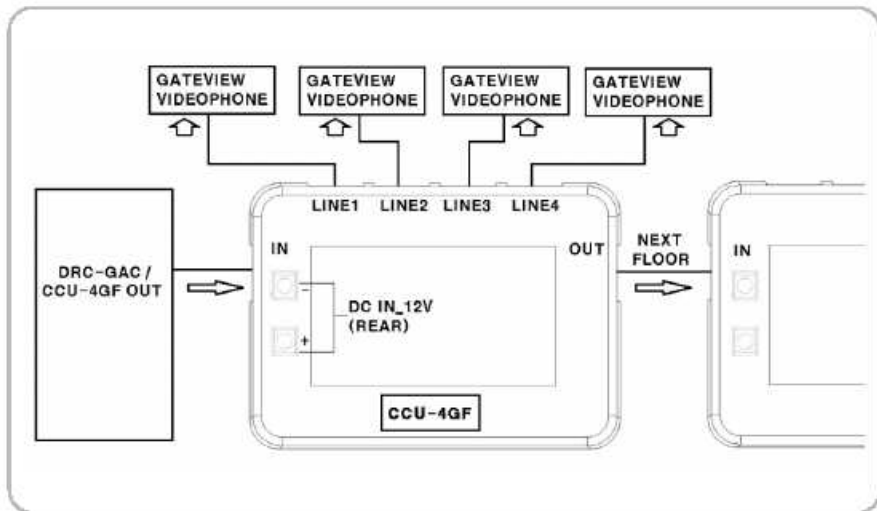

- DRC-GAC(LOBBY) CCU-4GF(1<sup>st</sup> FLOOR) → CCU-4GF(2<sup>ND</sup> FLOOR) → ... →  
GATEVIEW VIDEOPHONE : UTP CABLE [CAT.5] – MAX 300m

# PDF Compressor Free Version

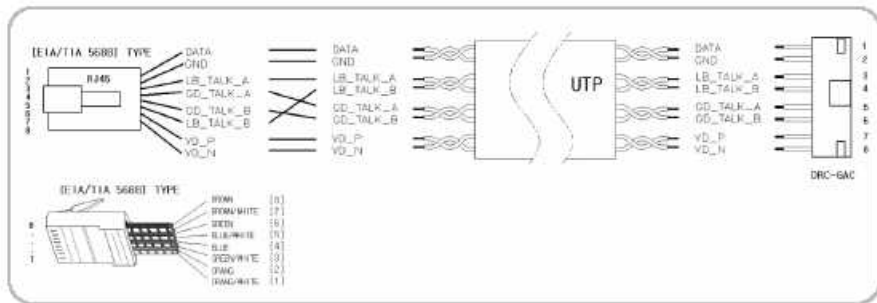



# PDF Compressor Free Version



## 5. Specification

Spec	Model	CCU-4GF [Floor Distributor]
Transmission type		LOBBY 8 lines (Polarity)
		(RJ45 CAT5 Patch Cable)
Rated Voltage		DC 12V / 80 mA (MAX)
Procedure		1. DRC-GAC/GAB UTP Line PCB → "IN" of CCU-4GF(input)
		2. "OUT" of CCU-4GF(output) → "IN" of CCU-4GF(extension)
		LINE 1,2,3,4 → Each monitor(Gate View Video Phone)
Distance		Max 300m : Common Entrance → Monitor
		(Possible to connect Max 40 PCS of Floor distributor)

# PDF Compressor Free Version

The logo for COMMAX, featuring the word "COMMAX" in a bold, blue, italicized sans-serif font. The letters are slightly shadowed, giving it a 3D appearance.

**COMMAX Co.,Ltd.**

513-11, Sangdaewon-dong, Jungwon-gu, Seongnam-si, Gyeonggi-do, Korea  
Int'l Business Dept. : Tel.; +82-31-7393-540-550 Fax.; +82-31-745-2133  
Web site : [www.commax.com](http://www.commax.com)

PM324GF00010

Printed In Korea / 2011.12.105